



SMART Clean – TDM*

Intelligent, Real-Time Boiler Diagnosis

The Challenge

The combustion of fossil fuels, fuel mixtures or refuse derived fuels is a complex process, in which even the slightest deviation from the original boiler design can promote unwanted development of corrosion, erosion and deposit formation on heating surfaces. These all reduce the efficiency and availability of the plant. In some plants, the process is not completely recorded and/or not known at every point in time and in this way deviations from normal conditions are not always clearly visible.

Information from the steam generation process is prepared and presented inadequately for the operating personnel. In addition, a deviation from measured values and/or a malfunction of the measuring system is not immediately apparent.

The influence of various fuel compositions and operating parameters on the deposit situation is sometimes not taken into account. Based on this, a selective and demand-driven cleaning of individual heating surfaces is not feasible. In this situation, a thermodynamic calculation of the entire power plant process is needed. Information on the interrelationships between feed water, steam, flue gas and individual plant components can be assessed and graphically presented.

Our Solution

With SMART Clean – TDM*, the entire power plant process is illustrated and thermodynamically balanced. In doing so, the process parameters of the individual power plant components are presented in a logical model that illustrates the process.

For a detailed process evaluation, heat and mass flow are balanced in real-time, temperature profiles and air consumption are calculated and fuel and flue gas mass flow are evaluated. Furthermore, a comparison between original boiler design and current operation is carried out in real-time.

Measured data, such as temperature or volume flow is validated and subjected to a plausibility check.

SMART Clean – TDM recognizes weak points in the steam generation process during operation, evaluates these and shows the most economical countermeasure.



*TDM = Thermodynamic Modelling

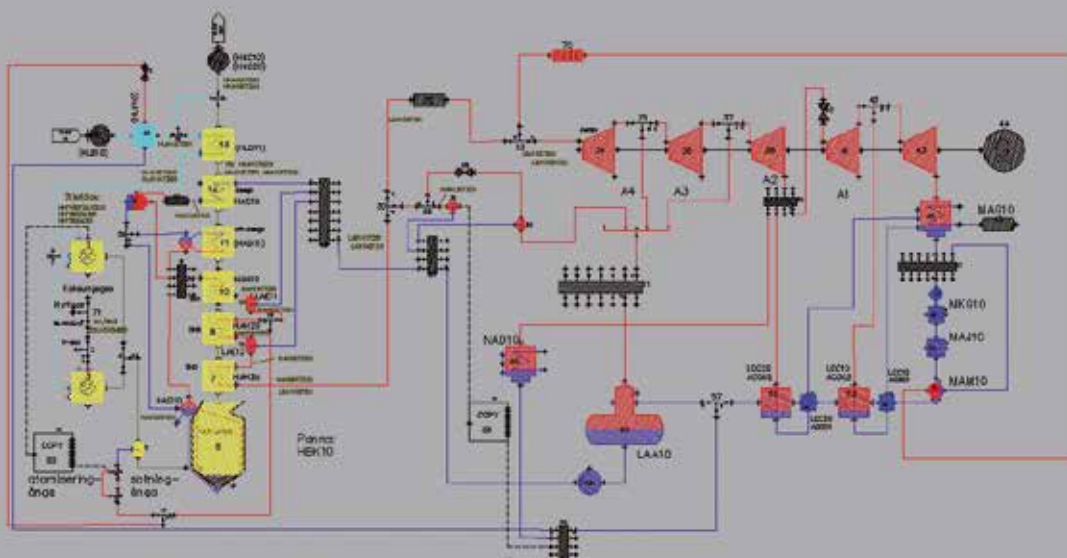

Best Possible Operation by Detailed Analysis and Evaluation of the Steam Generation Process

The Functional Principle

For SMART Clean – TDM, all relevant plant components are initially brought into relationship with one another in a model on the basis of the design data. Out of a components library, all needed power plant components are selected, from the fuel and air supply to the flue gas path and the water-steam circulation, and the associated process parameters are entered. To use the model during operation, signal lists from the DCS are used, from which SMART Clean – TDM reads the necessary process and measurement values for each calculation step fully automatically and in real-time. In addition, process data is tested online for plausibility. To do this, replacement values are determined and compared with the measurement data. If SMART Clean – TDM identifies a malfunction of the measuring systems, these replacement values are used for the calculation process and also indicated to the operator.

This boiler model then calculates e.g. heating surface effectiveness, temperature profiles, flue gas composition and pressure distribution.

With the assistance of what-if scenarios, process modifications that occur, such as variation of the fuel or air mass flow rate, can be simulated. In the process, the changes of the process parameters resulting (e.g., flue gas compositions, temperature progression, operating costs, etc.) are presented in a well-arranged manner.

🔗 Your Advantages:

- Illustration of the plant-specific processes and interrelationships
- Validation and plausibility check of the measuring system data
- Determination of missing measured values and/or additional process parameters, e. g., flue gas temperatures between the heating surfaces
- Calculation of heating surface effectiveness
- Basis for intelligent on-load boiler cleaning
- Identification of cost-saving potential
- Increase of plant efficiency and availability

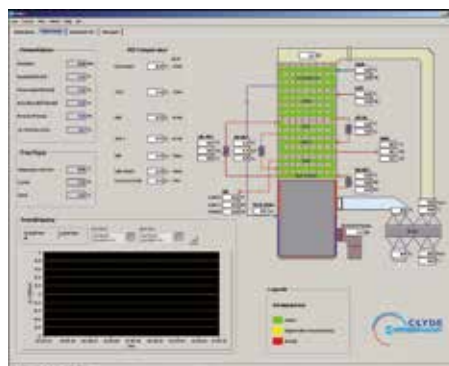

Top picture: Block model consisting of process components
Bottom picture: Operating interface of the SMART Clean – TDM system (example)



Clyde Bergemann GmbH

Schillwiese 20
D-46485 Wesel

T: +49 281 815 0
F: +49 281 5 37 68

Internet: www.cbpbg.com
eMail: info@de.cbpbg.com